

Glass Tube Full-View® Flowmeters



*Model 1110
Full-View Flowmeter
(NPT Connections)*



*Model 1140
Full-View Flowmeter
(Flange Connections)*

FEATURES AND BENEFITS

- Wide choice of application-specific materials and connections
- Rugged dowel-pin, side-plate construction
- Precision-bore, plain or ribbed borosilicate glass metering tubes
- Reliable, externally-adjustable packing glands for ease of maintenance
- Flanged or NPT connections with horizontal or vertical inlet and outlet orientation
- Connections rotatable 360° at 90° intervals

Brooks® 1110 and 1140 Series

DESCRIPTION

The Brooks® Full-View® glass tube meters are designed to offer a wide variety of meter configurations to meet a broad range of metering applications. The packing gland seal construction provides for long-term, leak-free, and reliable flow measurement.

SPECIFICATIONS

Capacities and Pressure Drops

150 mm scale, Rib Guided Tubes, Spherical Float:
Refer to Table 3

250 mm scale, Rib Guided Tubes, Spherical Float:
Refer to Table 4

250 mm scale, Rib Guided Tubes, Standard Float:
Refer to Table 5

127 mm scale, Rib Guided Tubes, Standard Float:
Refer to Table 6

Accuracy

Standard Flow Accuracy (127, 150, 250mm Tubes):
±2% Full Scale

Optional Flow Accuracy (127, 150, 250mm Tubes):
±1% Full Scale

Repeatability

0.5% Full Scale

Pressure Ratings

Refer to Table 1 for maximum non-shock pressure for rib guided and plain tapered tubes.

Pressure Equipment Directive (PED) 97/23/EC See Table 1

Scales

Standard: Detachable aluminum plate

Length: 127mm, 150mm and 250mm

Graduations: Choice of direct reading units, millimeter
or percentage of maximum flow

Ambient Temperature Limits

33°F to 125°F (1°C to 52°C)

Operating Fluid Temperature Limits

Maximum: 250°F (121°C) for metallic end fittings
Reduced ratings on meters with non-metallic end fittings. Refer to Table 1

Minimum: 33°F (1°C)

MATERIALS OF CONSTRUCTION:

Metering Tube

Borosilicate glass

Protective Tube Sleeve, Size 7 (1/2") and larger

UV stabilized polycarbonate

Floats (Figure 2)

Standard Sizes 2-7 (spherical): sapphire, tantalum, glass,
Carboloy®, 316 stainless steel, Monel® (Size 7 only)

Standard Sizes 8-13: 316 stainless steel

Optional Sizes 8-13: Hastelloy C®

Float Stops

Standard, Sizes 2-8: 316 SS spring

Optional, Sizes 2-8: Hastelloy C

Standard, Sizes 9-13: Aluminum for brass & steel fittings,
316 SS for 316 SS fittings

Guide Rods and Cartridges

Standard: 316 stainless steel

Optional: Hastelloy C

Housing and Window Bezel

Standard: Aluminum with polyurethane paint

Optional: 18-8 stainless steel

Data Sheet

DS-VA-1110-1140-eng

April, 2011

Brooks® 1110 and 1140 Series

End Fittings

316 stainless steel, steel, Hastelloy C, CPVC Sizes 2-8, PVC Sizes 9-10, brass, (Brass, Hastelloy C, CPVC/PVC fittings not available with flanged connection)

Window

Scratch resistance, UV stabilized polycarbonate

Packing Material

Standard: Teflon®, Neoprene®, Viton® fluoroelastomers

O-rings

Standard: Teflon®, Buna, Viton® fluoroelastomers

Gland Rings

Standard: Steel
Optional: 18-8 stainless steel

Gland Followers

Standard: Sizes 2-9 aluminum, Sizes 10-13 steel
Optional: 18-8 stainless steel

Side Plate Gaskets

Anchorite

Bolts

18-8 stainless steel

Connection Orientation

Vertical or horizontal optional on inlets and outlets
Connection rotatable 360° at 90° intervals

Connections

Standard:
150 lbs, 300 lbs RF flanges per ANSI B 16.5
NPT female connections
(Refer to Table 2)

Optional:

125/175 RA flange finish
Flat faced flanges

Meter Dimensions

Refer to Figure 1

Ordering Information and Model Code

Refer to Tables 7 through 8

OPTIONAL EQUIPMENT

Mountings, Valves, Flow Controller

- **Mountings:** Brackets for flush or front of panel
- **Valves:** Available for connection Sizes 1/4" through 1" only. Horizontal stem in outlet or inlet and fitting Sizes 2 through 10.
- **Flow Controller:** Brass or 316 stainless steel integrally piped to Sizes 2-6. See Brooks publications DS-FCA.

Table 1 Pressure Ratings

Meter Size	End Fitting Material	Maximum Operating Pressure (psig) ²			
		@ 70°F (21°C)	@ 150°F ¹ (66°C)	@ 250°F (121°C)	PED CAT.
2	CPVC	100	100	Not Available	SEP
	Metal	500	500	500	
6	CPVC	100	100	Not Available	
	Metal	450	450	450	
7	CPVC	100	100	Not Available	
	Metal	350	350	350	
8	CPVC	100	100	Not Available	
	Metal	300	300	300	
9	PVC	100	100 (Note 1)	Not Available	
	Metal	175	175	175	
10	PVC	100	100 (Note 1)	Not Available	
	Metal	100	100	100	
12	Metal	75	75	75	SEE NOTE 3
13	Metal	100	100	100	

NOTES:

- ¹ Maximum temperature rating for nonmetal end fittings is 150°F (66°C) for all materials except PVC, which is 140°F.
- ² Flanged unit pressure ratings are limited to ANSI flange or tube ratings whichever is lower.
- ³ Sizes 12 and 13 do not conform to Pressure Equipment Directive 97/23/EC, therefore it cannot be sold or used in the EU/EFTA.

Table 2 Connections

Meter Size	Model 1110 Inlet&Outlet Horizontal (NPT)	Model 1114 Inlet&Outlet Vertical (NPT)	Model 1140 Inlet&Outlet Horizontal (Flange)	Model 1144 Inlet&Outlet Vertical (Flange)
2 to 6	1/4"	1/4"	1/2"	1/2"
7 and 8	1/2"	1/2"	1/2"	1/2"
9	3/4"	3/4"	1"	1"
10	3/4"	1"	1"	1"
12	1-1/2"	1-1/2"	1-1/2"	1-1/2"
13	1-1/2"	2"	2"	2"

Brooks® 1110 and 1140 Series

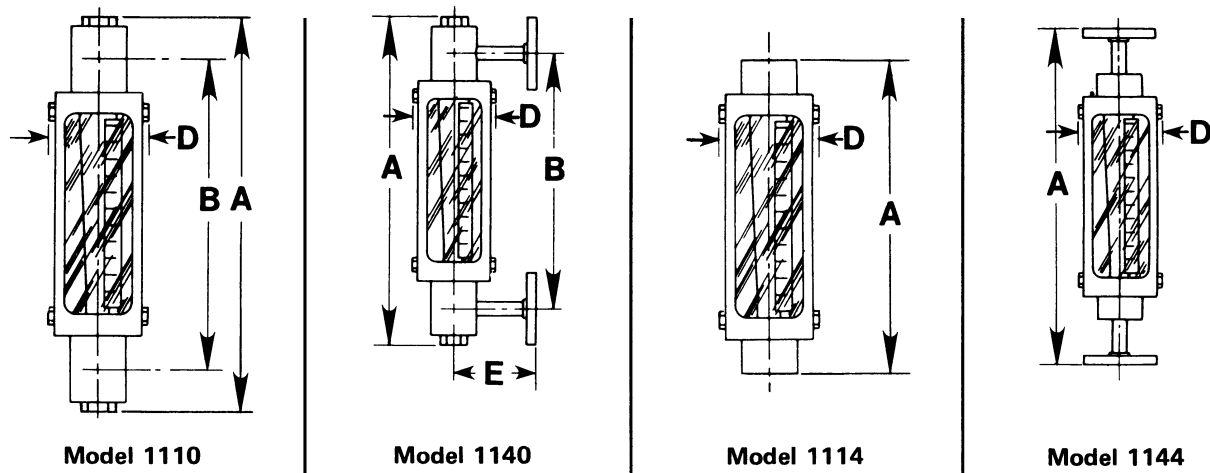

All Dimensions in Inches

Meter Size	1110 - 1140				1114		1144		All Meters	All Meters
	Nominal Scale Length (MM)				Nominal Scale Length (MM)		Nominal Scale Length (MM)			
	127		250		127	250	127	250		
	A	B	A	B	A	A	A	A		
2-6*	10.12	8.59	15.12	13.59	9.63	14.63	14.88	19.88	2.38	3.5
7&8	15.38	11.5	20.38	16.5	12	17	17.88	22.88	3.25	3.5
9	17	12.5	22	17.5	12.25	17.25	17.75	22.75	3.75	4
10	17.88	12.5	22.88	17.5	12.25	17.25	17.5	22.5	4.44	4
12	20.12	15.5	25.12	20.5	15.88	20.88	21.38	26.38	4.38	5
13	21.25	15.5	26.25	20.5	15.12	20.12	20.63	25.63	4.88	5

* Also available in 150mm scale length. Dimensions are identical to 127mm scale length
Flange dimensions apply to 150# & 300# raised face or flat face flanges

All Dimensions in Millimeters

Meter Size	1110 - 1140				1114		1144		All Meters	All Meters
	Nominal Scale Length (MM)				Nominal Scale Length (MM)		Nominal Scale Length (MM)			
	127		250		127	250	127	250		
	A	B	A	B	A	A	A	A		
2-6*	257.0	218.2	384.0	345.2	244.6	371.6	378.0	505.0	60.5	88.9
7&8	390.7	292.1	517.7	419.1	304.8	431.8	454.2	581.2	82.6	88.9
9	431.8	317.5	558.8	444.5	311.2	438.2	450.9	577.9	95.3	101.6
10	454.2	317.5	581.2	444.5	311.2	438.2	444.5	571.5	112.8	101.6
12	511.0	393.7	638.0	520.7	403.4	530.4	543.1	670.1	111.3	127.0
13	539.8	393.7	666.8	520.7	384.0	511.0	524.0	651.0	124.0	127.0

* Also available in 150mm scale length. Dimensions are identical to 127mm scale length
Flange dimensions apply to 150# & 300# raised face or flat face flanges

Figure 1 Dimensions - 127mm, and 250mm Full-View Flowmeters

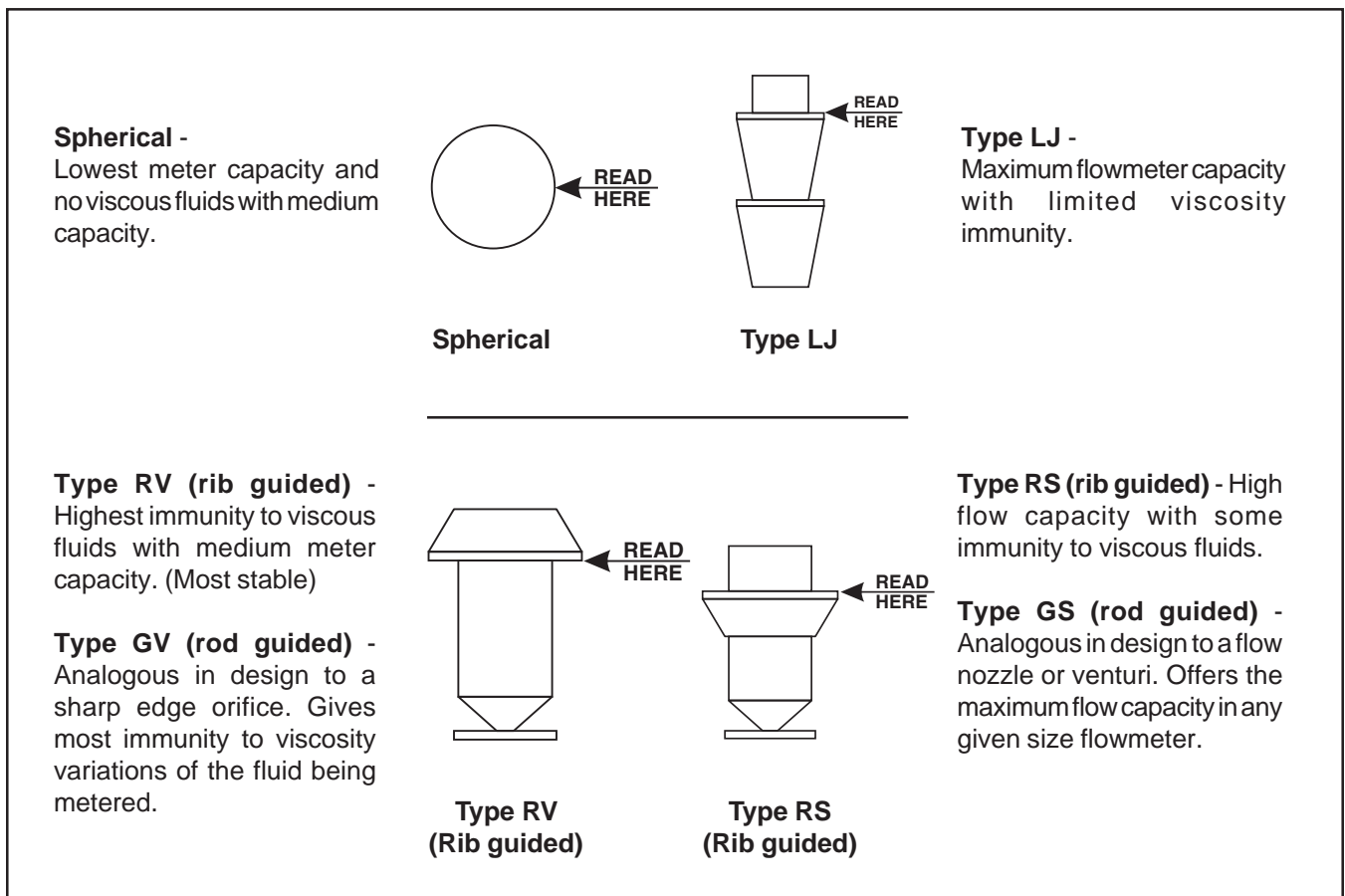

Figure 2 Float Types

Brooks® 1110 and 1140 Series

Table 3 Capacities 150mm Scale, Rib Guided Tube, Spherical Float

METER SIZE	TUBE	FLOAT	MAXIMUM FLOW RATE	
			WATER (CC/MIN.)	AIR @ 14.7 PSIA AND 70°F (21°C)
2	R-2-15-AAAA See Note Below*	GLASS *	0.59	50.0 SCC/MIN
		SAPPHIRE	1.10	79.0 SCC/MIN
		STN. STL.	2.60	150.0 SCC/MIN
		CARBOLOY	5.20	280.0 SCC/MIN
		TANTALUM	5.80	310.0 SCC/MIN
	R-2-15-AA	GLASS	0.96	83.8 SCC/MIN
		SAPPHIRE	1.86	128.0 SCC/MIN
		STN. STL.	4.34	245.0 SCC/MIN
		CARBOLOY	8.37	416.0 SCC/MIN
		TANTALUM	9.30	454.0 SCC/MIN
	R-2-15-D	GLASS	5.58	361.0 SCC/MIN
		SAPPHIRE	10.20	491.0 SCC/MIN
		STN. STL.	19.80	790.0 SCC/MIN
		CARBOLOY	31.90	1170.0 SCC/MIN
		TANTALUM	34.40	1250.0 SCC/MIN
	R-2-15-A	GLASS	16.1	0.8 SLPM
		SAPPHIRE	25.2	1.0 SLPM
		STN. STL.	44.2	1.6 SLPM
		CARBOLOY	67.7	2.3 SLPM
		TANTALUM	72.5	2.5 SLPM
	R-2-15-B	GLASS	50.6	2.3 SLPM
		SAPPHIRE	76.2	2.9 SLPM
		STN. STL.	127	4.4 SLPM
		CARBOLOY	189	6.4 SLPM
TANTALUM		202	6.7 SLPM	
R-2-15-C	GLASS	81.1	3.7 SLPM	
	SAPPHIRE	123	4.8 SLPM	
	STN. STL.	208	7.2 SLPM	
	CARBOLOY	312	10.1 SLPM	
	TANTALUM	333	10.6 SLPM	
6	R-6-15-A	GLASS	191	8.3 SLPM
		SAPPHIRE	284	10.6 SLPM
		STN. STL.	468	15.7 SLPM
		CARBOLOY	690	22.0 SLPM
		TANTALUM	735	23.3 SLPM
	R-6-15-B	GLASS	548	22.6 SLPM
		SAPPHIRE	809	28.6 SLPM
		STN. STL.	1290	41.6 SLPM
		CARBOLOY	1850	58.1 SLPM
		TANTALUM	1960	61.4 SLPM

* R-2-15-AAAA TUBE WITH GLASS FLOAT NOT AVAILABLE WITH 1% ACCURACY.

Table 4 Capacities 250mm Scale, Rib Guided Tube, Spherical Float

METER SIZE	TUBE	FLOAT	MAX. FLOW RATE	
			WATER (CC/MIN.)	AIR @ 14.7 PSIA AND 70°F (21.1°C)
2	R-2-25-D	GLASS	5.5	366 SCC/MIN
		SAPPHIRE	10.1	500 SCC/MIN
		STN. STL.	19.8	810 SCC/MIN
		CARBOLOY	32.2	1200 SCC/MIN
		TANTALUM	34.8	1280 SCC/MIN
	R-2-25-A	GLASS	16.8	0.84 SLPM
		SAPPHIRE	26.8	1.11 SLPM
		STN. STL.	46.5	1.7 SLPM
		CARBOLOY	71.5	2.46 SLPM
		TANTALUM	77.0	2.62 SLPM
	R-2-25-B	GLASS	49.0	2.2 SLPM
		SAPPHIRE	74.5	2.86 SLPM
		STN. STL.	124	4.3 SLPM
		CARBOLOY	186	6.2 SLPM
		TANTALUM	198	6.6 SLPM
R-2-25-C	GLASS	82	3.78 SLPM	
	SAPPHIRE	125	4.95 SLPM	
	STN. STL.	212	7.45 SLPM	
	CARBOLOY	318	10.3 SLPM	
	TANTALUM	342	10.9 SLPM	
R-6-25-A	GLASS	196	8.6 SLPM	
	SAPPHIRE	292	11.0 SLPM	
	STN. STL.	485	16.2 SLPM	
	CARBOLOY	715	22.8 SLPM	
	TANTALUM	760	24.2 SLPM	
R-6-25-B	GLASS	550	22.8 SLPM	
	SAPPHIRE	810	29.0 SLPM	
	STN. STL.	1300	42.0 SLPM	
	CARBOLOY	1860	58.5 SLPM	
	TANTALUM	1980	62.0 SLPM	
R-6M-25-1	GLASS	275	12.3 SLPM	
	SAPPHIRE	412	15.6 SLPM	
	STN. STL.	676	22.8 SLPM	
	TANTALUM	1087	33.9 SLPM	
7	R-7M-25-1	GLASS	605	24.2 SLPM
		STN. STL.	1286	42.7 SLPM
		MONEL	1360	44.8 SLPM

Brooks® 1110 and 1140 Series

Table 5 Capacities 250mm Scale , Rib Guided Tubes, Standard Float

METER SIZE	TUBE	FLOAT	WATER				AIR @ 14.7 PSIA AND 70°F (21°C)			
			GPM	LPM	PRESSURE DROP INCHES W.C.	VISCOSITY IMMUNITY CELING, CS (**)	SCFM	SLPM	PRESSURE DROP INCHES W.C.	PSI CRITICAL (*)
8	R-8M-25-2	8-RV-3	0.55	2.08	2.0	2.0	2.22	62.9	3.0	0
		8-RV-8	0.78	2.95	5.0	3.3	3.22	91.2	6.0	0
		8-RS-8	1.00	3.79	6.0	1.7	4.18	118.4	7.0	0
		8-RV-14	1.04	3.94	8.0	4.6	4.28	121.2	9.0	0
		8-RS-14	1.32	5.00	11.0	1.8	5.48	155.2	12.0	0
		8-RV-31	1.50	5.68	17.0	6.0	6.12	173.3	19.0	30
		8-RS-31	1.89	7.15	22.0	2.6	7.76	219.8	25.0	30
	8-LJ-48	3.01	11.39	45.0	1.0	13.01	368.4	51.0	30	
	R-8M-25-4	8-RV-3	0.78	2.95	4.0	2.0	3.17	89.8	4.0	0
		8-RV-8	1.09	4.13	7.0	3.7	4.45	126.0	8.0	0
		8-RS-8	1.40	5.30	10.0	1.8	5.86	166.0	11.0	0
		8-RV-14	1.45	5.49	12.0	5.4	5.88	166.5	14.0	0
		8-RS-14	1.83	6.93	17.0	1.9	7.56	214.1	19.0	0
		8-RV-31	2.06	7.80	23.0	7.0	8.32	235.6	28.0	30
8-RS-31		2.59	9.80	33.0	3.1	10.66	301.9	37.0	30	
8-LJ-48	4.88	18.47	93.0	1.0	20.32	575.5	106.0	30		
9	R-9M-25-1	9-RV-33	1.90	7.19	5.0	10.0	7.96	225.4	6.0	0
		9-RS-33	2.52	9.54	6.0	2.3	10.46	296.2	7.0	0
		9-RV-87	3.08	11.66	12.0	15.0	12.56	355.7	14.0	30
		9-RS-87	4.04	15.29	14.0	3.4	16.84	476.9	16.0	30
		9-LJ-160	6.88	26.04	31.0	1.0	30.45	862.3	35.0	30
	R-9M-25-3	9-RV-33	2.53	9.58	6.0	11.0	10.45	295.9	7.0	0
		9-RS-33	3.24	12.26	7.0	2.4	13.45	380.9	8.0	0
		9-RV-87	3.92	14.84	14.0	17.0	16.25	460.2	16.0	30
		9-RS-87	5.12	19.38	17.0	3.5	21.20	600.4	20.0	30
		9-LJ-160	9.65	36.53	43.0	1.0	44.18	1251.2	49.0	30
10	R-10M-25-1	10-RV-64	4.54	17.18	8.0	14.0	18.05	511.2	9.0	0
		10-RS-64	5.64	21.35	10.0	3.0	23.65	669.8	12.0	0
		10-RV-138	6.42	24.30	17.0	22.0	26.60	753.3	19.0	30
		10-RS-138	8.02	30.36	21.0	5.0	34.60	979.9	23.0	30
		10-LJ-238	14.91	56.43	52.0	1.0	66.00	1869.1	59.0	30
	R-10M-25-3	10-RV-64	6.28	23.77	11.0	15.0	25.76	729.5	13.0	0
		10-RS-64	7.84	29.67	15.0	3.7	32.15	910.5	17.0	0
		10-RV-138	8.84	33.46	23.0	23.0	36.10	1022.4	26.0	30
		10-RS-138	10.93	41.37	29.0	5.5	45.90	1299.9	33.0	30
		10-LJ-238	23.10	87.43	98.0	1.0	105.70	2993.4	112.0	30
12	R-12M-25-4	12-RV-221	9.33	35.31	8.0	28.0	37.81	1070.8	9.0	0
		12-RV-343	11.71	44.32	12.0	35.0	47.12	1334.4	14.0	30
		12-RS-221	12.46	47.16	9.0	4.0	50.65	1434.4	10.0	0
		12-RS-343	15.43	58.40	13.0	4.3	62.75	1777.1	15.0	30
		12-LJ-740	30.00	113.55	31.0	1.0	123.30	3491.9	36.0	30
	R-12M-25-5	12-RV-221	17.21	65.14	10.0	29.0	70.80	2005.1	11.0	0
		12-RV-343	20.95	79.30	15.0	36.0	86.45	2448.3	17.0	30
		12-RS-221	22.40	84.78	12.0	4.2	91.85	2601.2	14.0	0
		12-RS-343	26.90	101.82	18.0	4.5	112.00	3171.8	20.0	30
		12-LJ-740	67.60	255.87	65.0	1.0	299.50	8481.8	75.0	30
13	R-13M-25-1	13-RV-510	19.94	75.47	12.0	40.0	81.55	2309.5	14.0	0
		13-RV-760	23.79	90.05	18.0	50.0	96.00	2718.7	20.0	30
		13-RS-510	26.89	101.78	15.0	7.3	108.00	3058.6	17.0	0
		13-RS-760	31.85	120.55	21.0	9.0	131.00	3709.9	24.0	30
		13-LJ-1394	54.60	206.66	46.0	1.0				
	R-13M-25-3	13-RV-510	31.78	120.29	17.0	42.0	130.90	3707.1	19.0	0
		13-RV-760	37.60	142.32	24.0	52.0	155.20	4395.3	27.0	30
		13-RS-510	42.52	160.94	23.0	7.6	176.60	5001.3	26.0	0
		13-RS-760	49.55	187.55	32.0	9.3	217.70	6165.3	36.0	30

Table 6 Capacities 127mm Scale , Rib Guided Tubes, Standard Float

METER SIZE	TUBE	FLOAT	WATER				AIR @ 14.7 PSIA AND 70°F (21°C)			
			GPM	LPM	PRESSURE DROP INCHES W.C.	VISCOSITY IMMUNITY CELING, CS (**)	SCFM	SLPM	PRESSURE DROP INCHES W.C.	PSI CRITICAL (*)
8	R-8M-127-1	8-RV-3	0.50	1.89	2.0	2.0	2.05	58.1	2.0	0
		8-RV-8	0.74	2.80	3.0	3.3	3.01	85.2	4.0	0
		8-RS-8	0.92	3.48	4.0	1.7	3.84	108.7	4.0	0
		8-RV-14	0.96	3.63	6.0	4.6	3.95	111.9	6.0	0
		8-RS-14	1.22	4.62	6.0	1.8	5.03	142.4	7.0	0
		8-RV-31	1.38	5.22	11.0	6.0	5.60	158.6	13.0	30
		8-RS-31	1.70	6.43	13.0	2.6	6.98	197.7	15.0	30
	8-LJ-48	2.59	9.80	22.0	1.0	10.93	309.5	25.0	30	
	R-8M-127-4	8-RV-3	0.72	2.73	2.0	2.0	2.94	83.3	2.0	0
		8-RV-8	1.02	3.86	4.0	3.7	4.19	118.7	5.0	0
		8-RS-8	1.30	4.92	5.0	1.8	5.40	152.9	6.0	0
		8-RV-14	1.34	5.07	7.0	5.4	5.46	154.6	8.0	0
		8-RS-14	1.69	6.40	8.0	1.9	6.98	197.7	10.0	0
		8-RV-31	1.85	7.00	14.0	7.0	7.53	213.2	15.0	30
8-RS-31		2.30	8.71	16.0	3.1	9.45	267.6	18.0	30	
8-LJ-48	4.40	16.65	35.0	1.0	18.10	512.6	40.0	30		
9	R-9M-127-1	9-RV-33	1.70	6.43	4.6	10.0	7.00	198.2	6.0	0
		9-RS-33	2.20	8.33	5.3	2.3	9.05	256.3	6.0	0
		9-RV-87	2.64	9.99	11.5	15.0	11.08	313.8	13.0	30
		9-RS-87	3.46	13.10	13.0	3.4	14.40	407.8	15.0	30
	9-LJ-160	5.91	22.37	26.6	1.0	26.03	737.2	31.0	30	
	R-9M-127-3	9-RV-33	3.90	14.76	8.4	11.0	15.75	446.0	10.0	0
		9-RS-33	4.90	18.55	10.8	2.4	20.35	576.3	13.0	0
		9-RV-87	5.55	21.01	18.1	17.0	23.30	659.9	21.0	30
		9-RS-87	6.75	25.55	21.7	3.5	28.75	814.2	25.0	30
9-LJ-160		17.20	65.10	79.0	1.0	83.40	2361.9	90.0	30	
10	R-10M-127-1	10-RV-64	4.28	16.20	7.0	14.0	17.90	506.9	8.0	0
		10-RS-64	5.40	20.44	8.4	3.0	22.85	647.1	10.0	0
		10-RV-138	5.93	22.45	14.0	22.0	25.30	716.5	16.0	30
		10-RS-138	7.41	28.05	16.2	5.0	31.50	892.1	19.0	30
		10-LJ-238	13.65	51.67	36.0	1.0	57.90	1639.7	41.0	30
	R-10M-127-3	10-RV-64	6.02	22.79	9.2	15.0	24.33	689.0	11.0	0
		10-RS-64	7.56	28.61	11.4	3.7	30.80	872.3	13.0	0
		10-RV-138	8.01	30.32	17.2	23.0	33.45	947.3	20.0	30
		10-RS-138	9.94	37.62	21.0	5.5	41.63	1179.0	24.0	30
		10-LJ-238	22.47	85.05	61.0	1.0	109.30	3095.4	70.0	30
12	R-12M-127-1	12-RV-221	8.60	32.55	8.0	28.0	35.23	997.7	9.0	0
		12-RV-343	10.74	40.65	12.0	35.0	43.55	1233.3	14.0	30
		12-RS-221	11.49	43.49	8.0	4.0	47.10	1333.9	10.0	0
		12-RS-343	13.97	52.88	13.0	4.3	56.70	1605.7	15.0	30
		12-LJ-740	24.30	91.98	28.0	1.0	99.80	2826.3	32.0	30
	R-12M-127-3	12-RV-221	16.61	62.87	10.0	29.0	67.65	1915.8	11.0	0
		12-RV-343	19.68	74.49	14.0	36.0	80.30	2274.1	17.0	30
		12-RS-221	21.83	82.63	12.0	4.2	89.70	2540.3	13.0	0
		12-RS-343	24.72	93.57	16.0	4.5	101.80	2883.0	19.0	30
		12-LJ-740	72.00	272.52	57.0	1.0				
13	R-13M-127-1	13-RV-510	19.28	72.97	12.0	40.0	78.25	2216.0	14.0	0
		13-RV-760	22.90	86.68	17.0	50.0	92.80	2628.1	20.0	30
		13-RS-510	26.35	99.73	14.0	7.3	105.30	2982.1	16.0	0
		13-RS-760	31.30	118.47	20.0	9.0	126.10	3571.2	23.0	30
		13-LJ-1394	47.45	179.60	38.0	1.0				
	R-13M-127-3	13-RV-510	30.40	115.06	16.0	42.0	125.00	3540.0	18.0	0
		13-RV-760	34.90	132.10	22.0	52.0	144.20	4083.7	25.0	30
		13-RS-510	41.30	156.32	20.0	7.6	175.25	4963.1	23.0	0
		13-RS-760	46.50	176.00	27.0	9.3	199.80	5658.3	31.0	30

Brooks® 1110 and 1140 Series

Table 7 Ordering Information and Model Code for 1110-1140 Series, 127/150/250 mm, Ribbed Tube

MODEL INDUSTRIAL GLASS TUBE VARIABLE AREA FLOWMETER (127/150/250/600 MM, RIBBED TUBE)									
		CONNECTION SIZE							
		SIZE 2	SIZE 6	SIZE 7	SIZE 8	SIZE 9	SIZE 10	SIZE12	SIZE 13
111	THREADED	1/4"	1/4"	1/2"	1/2"	3/4"	3/4" (A)	1-1/2"	1-1/2" (B)
114	FLANGED	1/2"	1/2"	1/2"	1/2"	1"	1"	1-1/2"	2"
(A)		3/4" HORIZONTAL CONNECTIONS, 1" VERTICAL CONNECTIONS							
(B)		1-1/2" HORIZONTAL CONNECTIONS, 2" VERTICAL CONNECTIONS							

CODE	CONNECTION ORIENTATION
0 D	INLET-HORIZONTAL OUTLET-HORIZONTAL
4 D	INLET-VERTICAL OUTLET-VERTICAL
6 D	INLET-HORIZONTAL OUTLET-VERTICAL
7 D	INLET-VERTICAL OUTLET-HORIZONTAL

CODE	METER SIZE
C	SIZE 2
G	SIZE 6
H	SIZE 7
J	SIZE 8
K	SIZE 9
L	SIZE 10
M	SIZE 12
N	SIZE 13

		TUBE DESIGNATOR							
CODE		SIZE 2	SIZE 6	SIZE 7	SIZE 8	SIZE 9	SIZE 10	SIZE12	SIZE 13
0	R-2-15-A								
1	R-2-15-AA	R-6M-127-1	R-7M-127-1	R-8M-127-1	R-9M-127-1	R-10M-127-1	R-12M-127-1	R-13M-127-1	
2		R-6-15-A	R-7M-25-1	R-8M-127-4	R-9M-127-3	R-10M-127-3	R-12M-127-3	R-13M-127-3	
3	R-2-15-B	R-6-15-B		R-8M-25-2	R-9M-25-1	R-10M-25-1	R-12M-25-4	R-13M-25-1	
4	R-2-15-C	R-6-25-A		R-8M-25-4	R-9M-25-3	R-10M-25-3	R-12M-25-5	R-13M-25-3	
5	R-2-15-D	R-6-25-B							
6	R-2-25-A	R-6M-25-1							
7	R-2-25-B								
8	R-2-25-C								
A	R-2-15-AAAA								

		FLOAT DESIGNATOR							
CODE		SIZE 2-6	SIZE 7	SIZE 8	SIZE 9	SIZE 10	SIZE12	SIZE 13	
1		SPHERICAL	SPHERICAL	8-RV-3	9-RV-33	10-RV-64	12-RV-221	13-RV-510	
2				8-RV-8	9-RS-33	10-RS-64	12-RS-221	13-RS-510	
3				8-RS-8	9-RV-87	10-RV-138	12-RV-343	13-RV-760	
4				8-RV-14	9-RS-87	10-RS-138	12-RS-343	13-RS-760	
5				8-RS-14	9-LJ-160	10-LJ-238	12-LJ-740	13-LJ-1394	
6				8-RV-31					
7				8-RS-31					
8				8-LJ-48					

CODE	FLOAT MATERIAL
A	GLASS
B	SAPPHIRE
C	316 STN. STL.
D	CARBOLOY
E	TANTALUM
F	MONEL
G	HAST. C-276 (INCLUDED WITH HASTELLOY C OR PVC END FITTING ONLY)

111 0D J A 4 C D D A A TYPICAL MODEL CODE

Table 7 Ordering Information and Model Code for 1110-1140 Series, 127/150/250 mm, Ribbed Tube (Continued)

COD		SCALE			
A	NO INSCRIPTION (BLANK) (GAS)				
1	NO INSCRIPTION (BLANK) (LIQUID)				
B	MM SCALE (GAS)				
2	MM SCALE (LIQUID)				
C	0-100 LINEAR (GAS)				
3	0-100 LINEAR (LIQUID)				
D	% OF MAX FLOW (LIQUID)				
E	% OF MAX FLOW (GAS)				
F	CC/MIN WATER SP. GR. 1.0, VISC 1.0 CP				
G	CC/MIN AIR @ STP				
H	LPM AIR @ STP				
J	GPM WATER SP. GR. 1.0, VISC 1.0 CP				
K	LPM WATER SP. GR. 1.0, VISC 1.0 CP				
L	SCFM AIR @ STP				
M	SPECIAL INSCRIPTION (SPECIAL CALIBRATION NOT REQ'D) (GAS)				
4	SPECIAL INSCRIPTION (SPECIAL CALIBRATION NOT REQ'D) (LIQUID)				
N	SPECIAL CALIBRATION WITH SCALE 2% FS AIR (GAS)				
P	SPECIAL CALIBRATION WITH SCALE 2% FS WATER (LIQUID)				
Q	SPECIAL CALIBRATION WITH SCALE 2% FS OIL (VISCOSITY)				
R	SPECIAL CALIBRATION WITH SCALE 1% FS AIR (GAS)				
S	SPECIAL CALIBRATION WITH SCALE 1% FS WATER (LIQUID)				
CODE	MATERIALS OF CONSTRUCTION (Teflon O-ring and Packing - Standard)				
	FITTING	PACKING	O-RING	END CONNECTIONS	
A	STEEL	TEFLON	TEFLON	NPT OR FLANGE	
B	STEEL	NEOPRENE	BUNA	NPT OR FLANGE	
C	STEEL	VITON	VITON	NPT OR FLANGE	
D	316 S.S.	TEFLON	TEFLON	NPT OR FLANGE	
E	316 S.S.	NEOPRENE	BUNA	NPT OR FLANGE	
F	316 S.S.	VITON	VITON	NPT OR FLANGE	
G	BRASS	TEFLON	TEFLON	NPT ONLY	
H	BRASS	NEOPRENE	BUNA	NPT ONLY	
J	BRASS	VITON	VITON	NPT ONLY	
K	HAST C	TEFLON	TEFLON	NPT ONLY	
L	HAST C	NEOPRENE	BUNA	NPT ONLY	
M	HAST C	VITON	VITON	NPT ONLY	
N	PVC	TEFLON	TEFLON	NPT ONLY	
P	PVC	NEOPRENE	BUNA	NPT ONLY	
Q	PVC	VITON	VITON	NPT ONLY	
CODE	CONNECTION TYPE				
A	NPT				
B	150# R.F. FLG				
CODE	ACCESSORIES (SELECT UP TO 3)				
A	NONE				
C	ALL STAINLESS STEEL EXTERNAL TRIM AND SCALE				
G	HORIZONTAL VALVE ON INLET (TO SIZE 10 ONLY)				
H	HORIZONTAL VALVE ON OUTLET (TO SIZE 10 ONLY)				
J	TRIPOD BASE W/ SPIRIT LEVEL & LEVELING SCREWS FOR TABLE TOP USE				
M	FLUSH PANEL MOUNTING BRACKETS				
N	FRONT OF PANEL MOUNTING BRACKETS				
Q	CLEAN FOR OXYGEN SERVICE				
R	NIST TRACEABLE				
S	DUAL DETACHABLE SCALES				

111 0D J A 4 D D A A TYPICAL MODEL CODE

Brooks® 1110 and 1140 Series

Table 8 Approximate Weights (lbs.)

MODEL	SCALE LENGTH	METER SIZE						
		2-6	7	8	9	10	12	13
1110	127/250 MM	6	12	12	18	25	26	40
1140	127/250 MM	10	13	13	20	29	35	52

TRADEMARKS

Brooks Brooks Instrument, LLC
 Carboly General Electric Co.
 Full-View Brooks Instrument, LLC
 Hastelloy C Haynes International
 Monel Inco Alloys International Inc.
 Neoprene E.I. DuPont de Nemours & Co.
 Teflon E.I. DuPont de Nemours & Co.
 Viton DuPont Performance Elastomers

BROOKS SERVICE AND SUPPORT

Brooks is committed to assuring all of our customers receive the ideal flow solution for their application, along with outstanding service and support to back it up. We operate first class repair facilities located around the world to provide rapid response and support. Each location utilizes primary standard calibration equipment to ensure accuracy and reliability for repairs and recalibration. The primary standard calibration equipment to calibrate our flow products is certified by our local Weights and Measures Authorities and traceable to the relevant International Standards.

Visit www.BrooksInstrument.com to locate the service location nearest to you.

START-UP SERVICE AND IN-SITU CALIBRATION

Brooks Instrument can provide start-up service prior to operation when required. For some process applications, where ISO-9001 Quality Certification is important, it is mandatory to verify and/or (re)calibrate the products periodically. In many cases this service can be provided under in-situ conditions, and the results will be traceable to the relevant international quality standards.

CUSTOMER SEMINARS AND TRAINING

Brooks Instrument can provide customer seminars and dedicated training to engineers, end users and maintenance persons. Please contact your nearest sales representative for more details.

HELP DESK

In case you need technical assistance:

Americas ☎ 1-888-554-FLOW
 Europe ☎ +(31) 318 549 290 Within Netherlands ☎ 0318 549 290
 Asia ☎ +011-81-3-5633-7100



Due to Brooks Instrument's commitment to continuous improvement of our products, all specifications are subject to change without notice.

Brooks Instrument
 407 West Vine Street
 P.O. Box 903
 Hatfield, PA 19440-0903 USA
 T (215) 362 3700
 F (215) 362 3745
 E-Mail BrooksAm@BrooksInstrument.com
www.BrooksInstrument.com

Brooks Instrument
 Neonstraat 3
 6718 WX Ede, Netherlands
 T +31 (0) 318 549 300
 F +31 (0) 318 549 309
 E-Mail BrooksEu@BrooksInstrument.com

Brooks Instrument
 1-4-4 Kitasuna Koto-Ku
 Tokyo, 136-0073 Japan
 T +81 (0) 3 5633 7100
 F +81 (0) 3 5633 7101
 E-Mail BrooksAs@BrooksInstrument.com

