



Full Metal Variable Area Flow Meter and Counter

for Liquids and Gases



measuring
•
monitoring
•
analysing



Special
versions up to
600 bar

●

Nominal
diameter up to
DN 150



- Measuring range:
0.5 - 5.0...13 000 - 130 000 L/h water
0.015 - 0.15...240 - 2400 m³/h air
(20 °C, 1.013 bar)
- Accuracy class: 1.6
- p_{max}: PN 40 · t_{max}: -40...+350 °C
- Connection: Flange DN 15...DN 150
- Material: st. steel 1.4404/1.4571,
Hastelloy C-22, PTFE
- Option:
Contacts, analogue output with
HART® or PROFIBUS-PA®, counter



KOBOLD companies worldwide:

ALGERIA, ARGENTINA, AUSTRALIA, AUSTRIA, BELGIUM, BULGARIA, CANADA, CHILE,
CHINA, COLOMBIA, CZECH REPUBLIC, DOM. REPUBLIC, EGYPT, FRANCE, GERMANY,
INDIA, INDONESIA, IRAN, ITALY, MALAYSIA, MEXICO, MOROCCO, NETHERLANDS,
PERU, POLAND, SINGAPORE, SLOVAKIA, SPAIN, SWITZERLAND, THAILAND, TUNESIA,
UNITED KINGDOM, USA, VENEZUELA, VIETNAM

KOBOLD Messring GmbH
Nordring 22-24
D-65719 Hofheim/Ts.
☎ +49(0)6192 299-0
Fax +49(0)6192 23398
E-Mail: info.de@kobold.com
Internet: www.kobold.com

Model:
BGN



Functions

The fluid flows from bottom to top through the meter tube of the flow meter. The float is lifted until an annular gap between the meter ring and the cone-shaped float is produced which corresponds to the flow. The forces acting on the float are in equilibrium. The forces that are mainly acting on the float comprise buoyancy according to the principle of Archimedes, the flow force of the medium and the weight force. Each position of the float corresponds to a flow value measured during calibration, which is transferred to a scale. The BGN variable area flow meter consists of a meter tube with connections, a meter ring, and a conical float. By means of a magnet, the position of the float is transferred to an encapsulated follow magnet, which has been fitted to a pointer axle. The position of a second annular follow magnet fitted on the pointer axle is transferred to the scale by means of the pointer.

Application

The KOBOLD-BGN meter is suitable for flow measurement of liquid or gaseous products in pipes. It shows the current flow rate in volume or mass per unit in time.

Applications

Flow measurement, dosing, monitoring, adjusting and control of liquid and gaseous products. The meter's design makes it ideal for processes under difficult and rough operating conditions. The devices are available with additional electrical equipment for process monitoring and control

- A large spectrum of wetted materials
- Magneto-resistive signal transmission
- Gas- or liquid damping (option)
- Special design for high-pressure and high-temperature applications
- Excellent heat tracing technology (option)
- Double eddy current damping (special version)
- Self draining (special version)
- Backflow stop (special version)
- Flow Controller (special version)

Technical data

Sensor

Materials:	1.4404 (316 L) / 1.4571 (316 Ti), Hastelloy C-22, PTFE other materials on request
Process connection:	Flanges acc. EN 1092, ASME B16.5, DIN 2512, JIS, NPT, screw pipe connection, special connections on request
Nominal pressure:	PN 40, ASME C1150 / 300 (standard) (BGN-S/H) PN 16, ASME C1150 (standard) (BGN-P) higher pressure rates optional (max. 600 bar)
Process temperature:	-40 °C up to +200 °C (BGN-S/H without electr. output) -40 °C up to +150 °C (BGN-S/H with electr. output) -40 °C up to +350 °C (BGN-S/H with option V/H/W) -40 °C up to +125 °C (BGN-P)
Ambient temperature:	-40 °C up to +80 °C

Accuracy:

Liquid:	± 1.6 % of u. r. value (BGN-S/H) ± 2.0 % of u. r. value (BGN-P)
Gas:	± 1.8 % of u. r. value (BGN-S/H) ± 2.2 % of u. r. value (BGN-P)
Additional inaccuracy through transmitter (ES):	± 0.2 %
Repeatability:	± 0.5 % of u. r. value
Ingress protection:	IP 65 (Aluminium housing) IP 67 (Stainless steel housing)

Certification

Explosion protection:	BVS 03 ATEX H/B 112
CE-Marking:	Pressure Equipment Directive 97/23/EG

Display

Material:	Aluminum (stove-enameled) Stainless steel (as option)
Electr. outputs:	Inductive switch (standard) Inductive switch (safety design) Microswitch others on request
Ambient temperature:	-40 °C up to +80 °C (without switch) -40 °C up to +65 °C (with switch)



Technical data (continued)

Transmitter

- ES with HART®-protocol
- ES with HART®-protocol and 2 NAMUR-switches
- ES with HART®-protocol and 1 NAMUR-switch / 1 pulse output
- ES with Profibus-PA®
- ES with HART®-protocol and counter module

Power supply:	14 - 30 V _{DC}
Output:	passive, galvanically isolated
Currency:	4 - 20 mA
Binary 1 and 2:	Ui = 30 V, Ii = 20 mA, Pi = 100 mW
Input Binary:	Counter reset (only for ES with counter module)
Ambient temperature:	-40 °C up to +70 °C

Certification

Explosion protection:	DMT 00 ATEX E 075
Type of protection:	 II 2G EEx ia IIC T6
CE-Marking:	Explosion Protection Directive 94/9/EG

Additional options and special versions:

- Other materials
- Other flange versions and sizes
- Certifications
- Display with pressure compensations against condensate build up
- Microswitch
- Inductive switches with safety design
- Double eddy current damping
- Self draining
- Backflow stop
- Flow controller
- specialy low pressure loss



Order details for liquids (Order example: BGN-S 105C A 0 000 S 1 0)

Model	Measuring range water [L/h]	Measuring range air at 20 °C, 1013 mbar [m³ _N /h]	Nominal diameter	Pressure stage (DIN-flange)	Max. pressure loss [mbar]	Code ²⁾ flange DIN EN 1092-1 Form B1	Code ²⁾ flange ASME Class 150 RF
BGN-S = st. st. measuring tube	0,5 - 5 (0,7 - 7) ¹⁾⁴⁾	0,015 - 0,15	DN 15, (3/4")	PN 40	40	305B A	202R A
	1 - 10 (1,2 - 12) ¹⁾⁴⁾	0,03 - 0,3	DN 15, (3/4")	PN 40	44	305B B	202R B
	1,6 - 16 (2 - 20) ¹⁾⁴⁾	0,145 - 0,48	DN 15, (3/4")	PN 40	40	305B C	202R C
	2,5 - 25 ³⁾⁴⁾	0,075 - 0,75	DN 15, (3/4")	PN 40	40	305B D	202R D
	4 - 40 ³⁾⁴⁾	0,13 - 1,3	DN 15, (3/4")	PN 40	40	305B E	202R E
	5 - 50	0,15 - 1,5	DN 15, (3/4")	PN 40	40	305B F	202R F
	7 - 70	0,2 - 2,1	DN 15, (3/4")	PN 40	40	305B G	202R G
	10 - 100	0,3 - 3,0	DN 15, (3/4")	PN 40	60	305B H	202R H
	16 - 160	0,5 - 4,6	DN 15, (3/4")	PN 40	60	305B I	202R I
	25 - 250	0,7 - 7,0	DN 15, (3/4")	PN 40	60	305B J	202R J
	40 - 400	1,0 - 11	DN 15, (3/4")	PN 40	70	305B K	202R K
	60 - 600	1,7 - 17	DN 15, (3/4")	PN 40	80	305B L	202R L
	0,5 - 5 (0,7 - 7) ¹⁾⁴⁾	0,015 - 0,15 ¹⁾⁴⁾	DN 25, 1"	PN 40	40	309B A	203R A
	1 - 10 (1,2 - 12) ¹⁾⁴⁾	0,03 - 0,3 ¹⁾⁴⁾	DN 25, 1"	PN 40	44	309B B	203R B
	1,6 - 16 (2 - 20) ¹⁾⁴⁾	0,145 - 0,48 ¹⁾⁴⁾	DN 25, 1"	PN 40	40	309B C	203R C
	2,5 - 25 ³⁾⁴⁾	0,075 - 0,75 ³⁾⁴⁾	DN 25, 1"	PN 40	40	309B D	203R D
	4 - 40 ³⁾⁴⁾	0,13 - 1,3 ³⁾⁴⁾	DN 25, 1"	PN 40	40	309B E	203R E
	5 - 50	0,15 - 1,5	DN 25, 1"	PN 40	40	309B F	203R F
	7 - 70	0,2 - 2,1	DN 25, 1"	PN 40	40	309B G	203R G
	10 - 100	0,3 - 3,0	DN 25, 1"	PN 40	60	309B H	203R H
16 - 160	0,5 - 4,6	DN 25, 1"	PN 40	60	309B I	203R I	
25 - 250	0,7 - 7,0	DN 25, 1"	PN 40	60	309B J	203R J	
40 - 400	1,0 - 11	DN 25, 1"	PN 40	70	309B K	203R K	
60 - 600	1,7 - 17	DN 25, 1"	PN 40	80	309B L	203R L	
BGN-P = st. st. measuring tube, PTFE-casing	100 - 1000	3 - 30	DN 25, 1"	PN 40	60	309B M	203R M
	160 - 1600	4 - 46	DN 25, 1"	PN 40	70	309B N	203R N
	250 - 2500	7 - 70	DN 25, 1"	PN 40	100	309B P	203R P
	400 - 4000 ³⁾⁹⁾	11 - 110 ³⁾⁹⁾	DN 25, 1"	PN 40	240	309B Q	203R Q
	250 - 2500	7 - 70	DN 40, 1 1/2"	PN 40	50	317B P	205R P
	400 - 4000	11 - 110	DN 40, 1 1/2"	PN 40	120	317B Q	205R Q
BGN-H = Hastelloy measuring tube	600 - 6000	17 - 170	DN 40, 1 1/2"	PN 40	180	317B R	205R R
	400 - 4000	11 - 110	DN 50, 2"	PN 40	80	321B Q	206R Q
	600 - 6000	17 - 170	DN 50, 2"	PN 40	90	321B R	206R R
	1000 - 10000	29 - 290	DN 50, 2"	PN 40	110	321B S	206R S
	1600 - 16000	46 - 460	DN 50, 2"	PN 40	230	321B T	206R T
	2500 - 25000 ³⁾⁹⁾	70 - 700 ³⁾⁹⁾	DN 50, 2"	PN 40	500	321B U	206R U
	1600 - 16000	46 - 460	DN 80, 3"	PN 40	70	331B T	208R T
	2500 - 25000	70 - 700	DN 80, 3"	PN 40	100	331B U	208R U
	4000 - 40000	110 - 1100	DN 80, 3"	PN 40	350	331B V	208R V
	4000 - 40000	110 - 1100	DN 100, 4"	PN 16	120	335B V	210R V
	6000 - 60000 (5500 - 55000) ¹⁾	170 - 1700	DN 100, 4"	PN 16	360	335B W	210R W
	8000 - 80000 ³⁾	240 - 2400 ³⁾	DN 100, 4"	PN 16	600	335B X	210R X
	10000 - 100000 ³⁾⁷⁾	-	DN 100, 4"	PN 16	on request	335B 2	210R 2
	4000 - 40000 ³⁾	on request	DN 125, 5"	PN 16	on request	340B X	211R X
80000 - 80000 ³⁾	on request	DN 125, 5"	PN 16	on request	340B X	211R 2	
100000 - 100000 ³⁾	on request	DN 125, 5"	PN 16	on request	340B 2	211R 3	
100000 - 1000000 ³⁾⁸⁾	on request	DN 150, 6"	PN 16	on request	345B 2	212R 2	
130000 - 1300000 ³⁾⁸⁾	on request	DN 150, 6"	PN 16	on request	345B 4	212R 4	



Continuation order details for liquids (Order example: BGN-S 105C A 0 000 S 1 0)

Heating ³⁾ / cooling	Damping ³⁾ / spring stop	Draining body	Certificates	Display	Scale	Electrical output
<p>0 = with</p> <p>1 = with heating Ermeto 12 mm</p> <p>2 = with heating DIN-flange DN 15/PN 40</p> <p>3 = with heating ANSI-flange 1/2" Class 150</p>	<p>00 = without</p> <p>R0 = with flow restrictor for gas measuring⁵⁾</p> <p>F0 = with liquid damping</p> <p>G0 = with gas damping</p> <p>A0 = with spring stop</p> <p>S0 = with gas damping and spring stop⁶⁾</p>	<p>0 = without draining body</p> <p>L = with self draining body</p>	<p>0 = without certificate</p> <p>1 = Certificate of compliance with the order 2.1</p> <p>2 = Certificate of compliance with the order 2.2</p> <p>B = Inspection certificate with material certificate 3.1</p> <p>C = Inspection certificate with material certificate 3.2</p>	<p>S = aluminium</p> <p>V = aluminium, assembled at distance up to 350 °C</p> <p>E = stainless steel</p> <p>H = stainless steel, assembled at distance up to 350 °C</p> <p>T = aluminium with pressure compensation</p> <p>W = aluminium with pressure compensation, assembled at distance up to 350 °C</p>	<p>Water</p> <p>1 = %-scale</p> <p>2 = measuring range</p> <p>Media</p> <p>4 = %-scale</p> <p>5 = measuring range</p> <p>Please specify mediadata in plain text (see below)</p>	<p>0 = without</p> <p>1 = 1 inductive switch</p> <p>2 = 2 inductive switches</p> <p>6 = transmitter ES with HART®, EEx ia, 4-20 mA</p> <p>7 = transmitter ES with HART®, EEx ia, 4-20 mA and 2 Namur-switches</p> <p>8 = transmitter ES with HART®, EEx ia, 4-20 mA, 1 Namur-switch and 1 pulse output</p> <p>9 = electrical transmitter with Profibus PA®, EEx ia</p> <p>I = 4-20 mA with HART® and counter module</p>

Reference conditions: water at 20 °C, 1 mPas

- 1) Different measuring range for model BGN-P (PTFE-chasing)
- 2) Other flange connections: Form B1, N, D, JIS or Class 300 on request
- 3) Not for model BGN-P (PTFE-casing)
- 4) Not for model BGN-H (Hastelloy)
- 5) Only up to measuring range: 40 L/h
- 6) Only for nominal diameter DN 100
- 7) Damping spring stop not possible
- 8) Only available with forward advanced indicating housing
- 9) Not available with heating/cooling

For the right design of the flowmeter

we need the following data:
 measuring range with unit, measured media,
 process temperature and pressure, viscosity,
 operating density (liquids), norm density (gases),
 mechanical connection

Dimensions

Display: aluminium

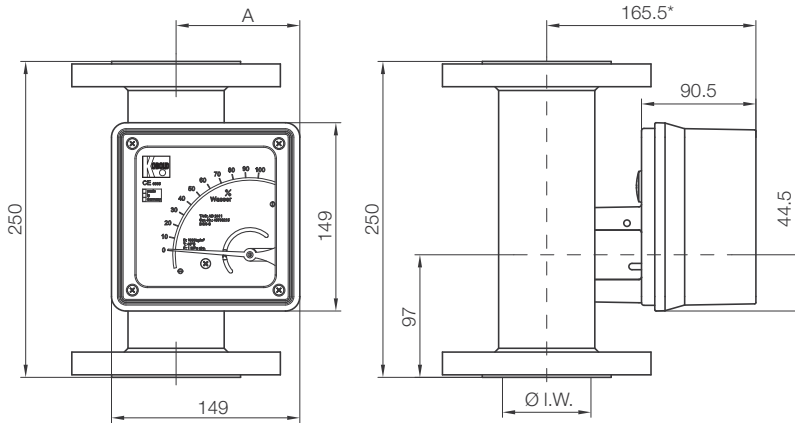

Display: stainless steel

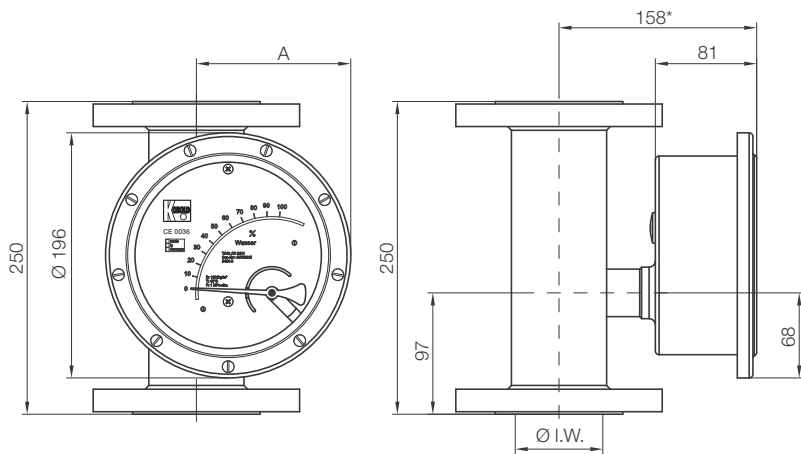

DN	PN	I. W.	A (aluminium)	A (st. steel)
15	40	26	74	100
25	40	32	77	103
40	40	46	85	110
50	40	70	98	123
80	40	102	114	140
100	16	125	127	153
125	16	150	142	166
150	16	159	148	171

Dimensional deviations:

* +100 mm with forward advanced display and generally at DN125 and DN150